

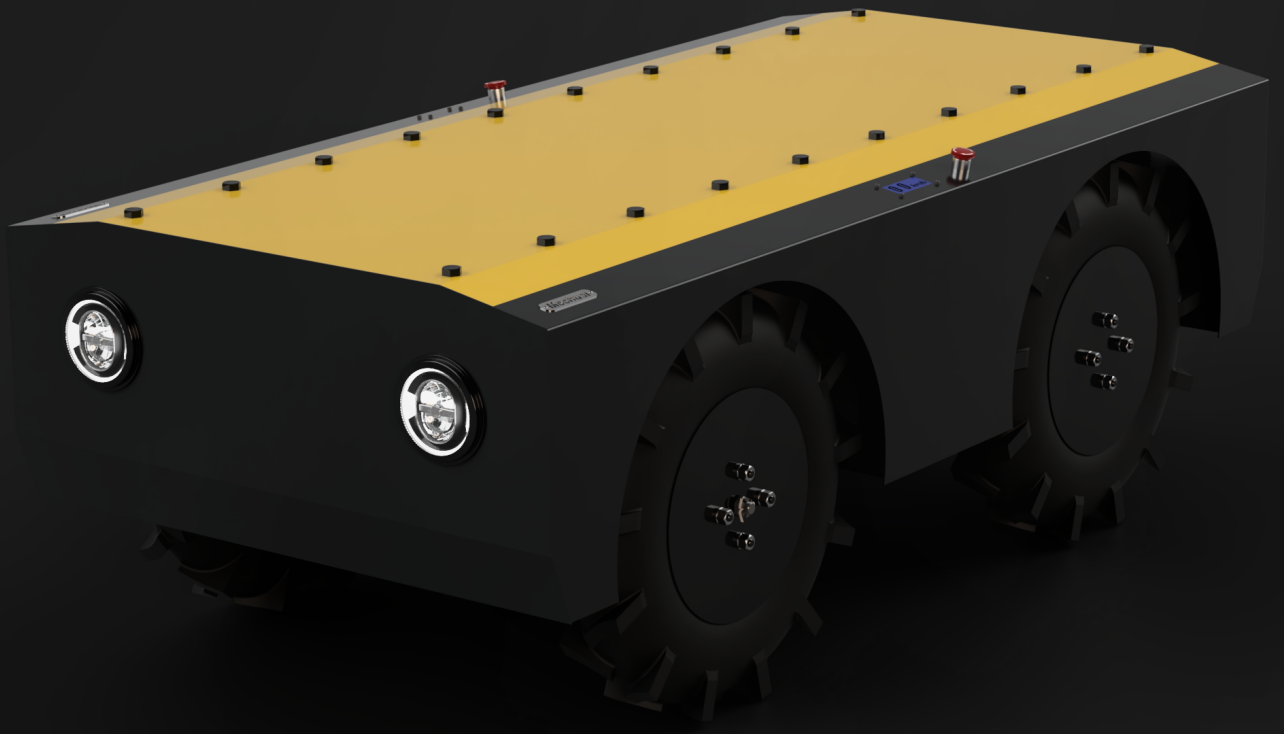

MechUAL



Mech_Bot

Mechual Technologies Pvt. Ltd



Robotic Development Platform for Rapid Prototyping



High Load Capacity



All Terrain Capability



EV Based Mobility



Supports access to more advanced automatic driving system

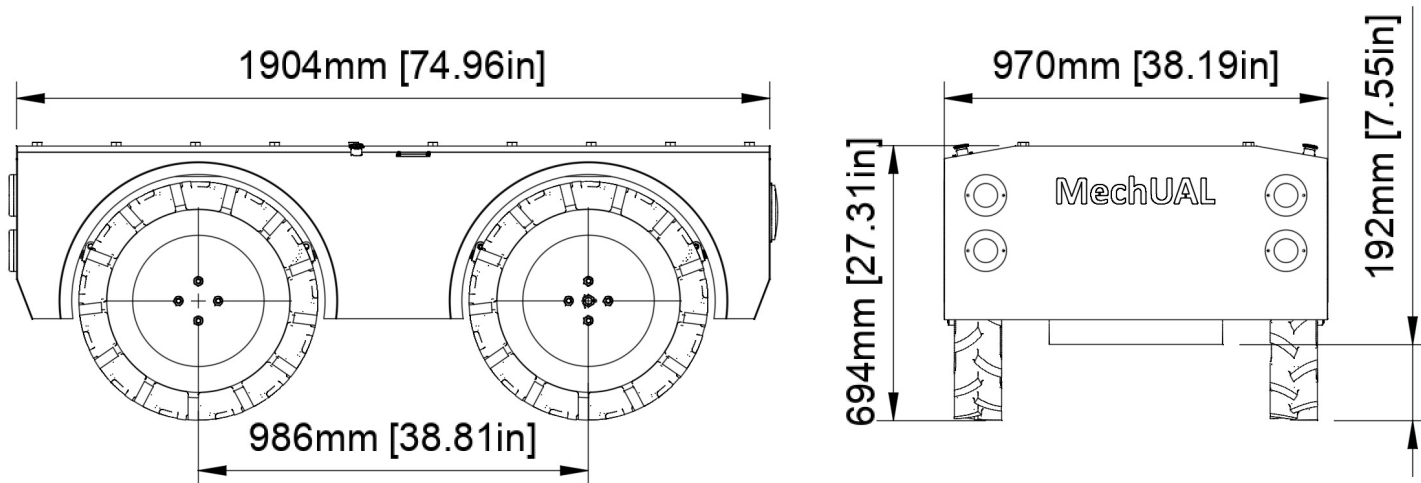

Technical Specification

SIZE AND WEIGHT	
EXTERNAL DIMENSIONS (L x W x H)	1094 mm x 973 mm x 693 mm
WEIGHT	365 kg
WHEELS	600 mm
GROUND CLEARANCE	180 mm
SPEED AND PERFORMANCE	
MAX PAYLOAD	1000 KG
ALL-TERRAIN PAYLOAD	600 KG
MAX SPEED	25 kmph
DRIVE FORM	Rear Wheel Differential Drive
SUSPENSION FORM	Leaf Spring Suspension
MAX GRADIENT	25°
TURNING MECHANISM	Front Wheel Ackerman Steering
BATTERY AND POWER SYSTEM	
BATTERY CHEMISTRY	NMC
CAPACITY	60V 35Ah
RUNTIME - NOMINAL USAGE	3 Hours
CHARGE TIME	5 Hours
USER POWER	12V 10A



MechUAL Technologies

Email:- mechualtechnologies@gmail.com

Tel:- +91 9909008703
+91 9106495655